

## Overview

FM Series, General Electronics Racks for Small Networking, AV, Telecom & lab application. Racks manufactured out of steel sheet punched, formed, welded and Powder coated with highest quality standards under stringent ISO 9001 | ISO 14001 | ISO 27001 | ISO 45001 Manufacturing & Quality management system to ensure highest quality product.

Standard for Racks configuration will be welded frame integrated with side panel and vented top cover with fan mounting provision, Associated with Front Glass Door with lock & Key and Back Metal door with lock & key and freestanding on floor with 4 No casters wheels with 2 No with brakes and 2 No without brakes



Available in 6RU ~32RU Variants with 600 Depth configurations and 600 Width configurations

Floor Mount Racks - FM Series Configurator Drawing with Critical Parts

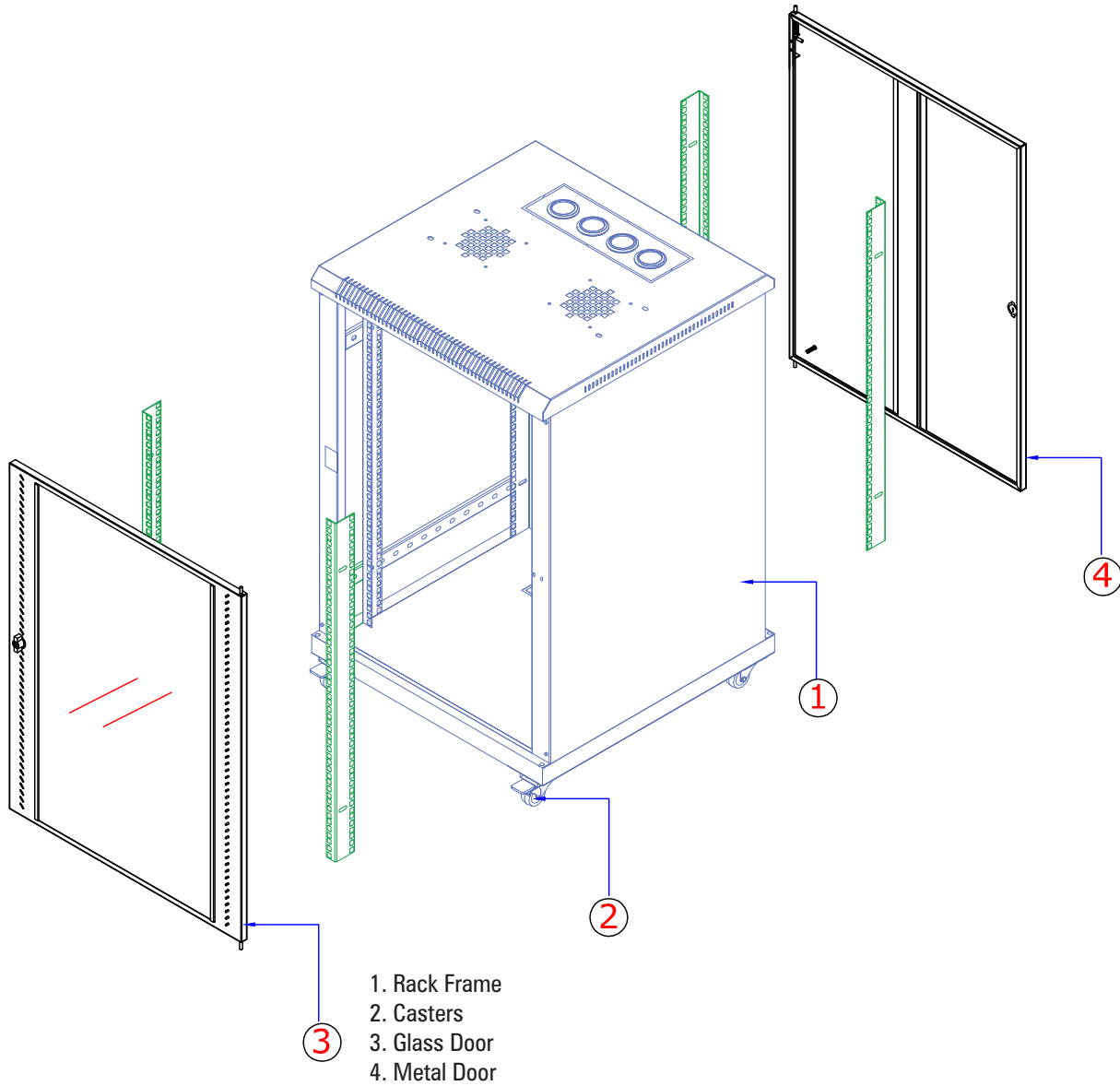

Features

- Conforms to DIN 41494 or Equivalent EIA /ISO / EN / CEA Standard
- Adjustable mounting depth
- 4 No Adjustable, 19" verticals with Punched 10 mm Square Hole and Universal 12.7mm-15.875mm-15.875mm alternating hole pattern offers greater mounting flexibility, maximizes usable mounting space.
- Universal 44.45MM Pitch Holes For DIN Standard Racks
- State-of-the-art manufacturing methods provide the best product quality and fastest delivery in the industry
- 100% assured compatibility with all equipments conforming to DIN 41494 (General industrial standard for equipments)
- Powder coated finish with Seven tank pretreatment process meeting ASTM standard
- Grounding & Bonding Options
- Fan module Mount Provision on top Cover

## Accessories:

- Cable Organisers
- Power Distribution Units
- Shelves
- Fan Modules
- Rack ground Kit

Technical Data:	
Basic Frame	Steel
Construction	Welded
Top & Bottom Cover	Welded to Frame with Cable entry exit cut outs
Front Door	Lockable Toughened Glass Door
Rear Door	Lockable Steel Door
19" Mounting Angle	Formed Steel
Std. Equipment Mounting	DIN Std. 10mm Sq. Slots
Standard Finish	Powder coated
Standard Colour	Grey & Off White OR Black
Standard Mounting	Caster wheels (2 with Brake & 2 without Brake)
Rack Standard	Conforms to DIN 41494 or equivalent standard
Static Load	150Kg

Model Matrix & Dimensions									
FM Series	H	h	W	w	w1	D	d	d1	Caster-type
6UX600x600	464	6U	600	19"	451	600	560	445	Type-2
9UX600x600	597	9U	600	19"	451	600	560	445	Type-2
12UX600x600	730	12U	600	19"	451	600	560	445	Type-2
15UX600x600	864	15U	600	19"	451	600	560	445	Type-2
17UX600x600	952	17U	600	19"	451	600	560	445	Type-2
22UX600x600	1175	22U	600	19"	451	600	560	445	Type-2
27UX600x600	1397	27U	600	19"	451	600	560	445	Type-2
32UX600X600	1620	32U	600	19"	451	600	560	445	Type-2

1U = 44.45 mm

Note :

1. It is recommended to distribute the Load along with U space in the Rack
2. Other models can be manufactured on request.
3. Dimension are in MM

DESCRIPTION	HEIGHT-(MM)
Type-2	85

## Abbreviations

Overall Height	H
Usable Height	h
Overall width	W
Usable width	w
Usable width Between Front MTG. Angles	w1
Overall Depth	D
Usable Depth	d
Usable Depth From Front & Rare Mounting Angle	d1

